

# USER MANUAL

## **Label counter**



*Please keep the original packaging in case you need to return the unit.  
If we receive the system in non-original packaging, the warranty may be void.*

## How to load the roll

---

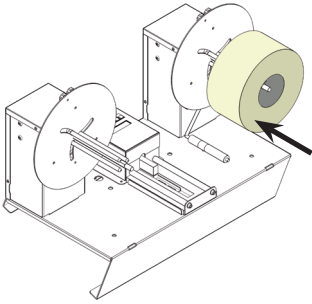

### **STEP 1**

Load the roll of media onto the unwinding side (where is the tension arm located).

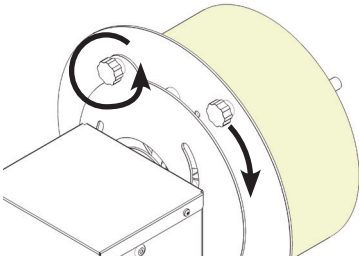

### **STEP 2**

Hold the roll adjusting the core holder and fix it using the two black knobs.

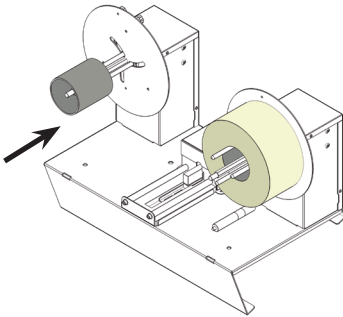

### **STEP 3**

Load the empty core onto the rewinding side.

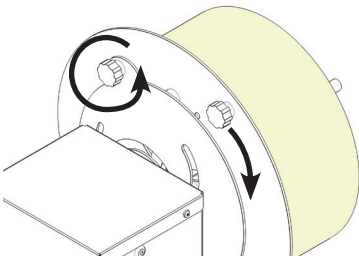

### **STEP 4**

Hold the core adjusting the core holder and fix it using the two black knobs.

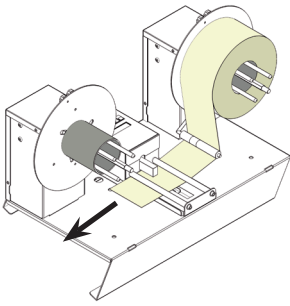

**STEP 5**

Pull the media under the tension arm, then feed it under the two aluminum cylinders located on the counter module.

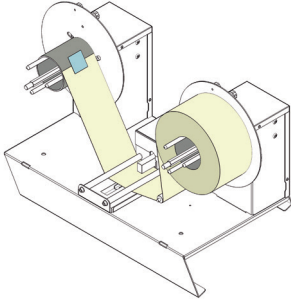

**STEP 6**

Secure the media onto the empty core.

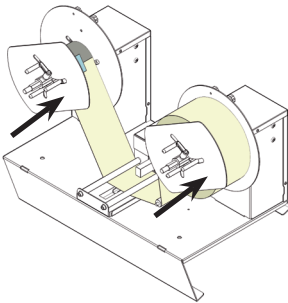

**STEP 7**

Install the outer discs.

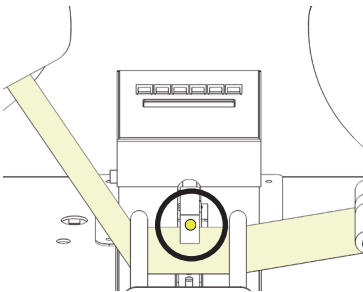

**STEP 8**

If required, adjust the sensor's sensitivity.

## How adjust the sensor's sensitivity

---

- Keep pushed the yellow button on sensor (\*) for at least 2 seconds and then release it.
- Yellow led will be blinking for few seconds. While blinking, move the media back and forth through the sensor for few seconds.
- The yellow led will flash twice confirming you've successfully completed the teach procedure. The unit is now operative

**NB. Repeat this procedure every time you change the type of media.**

*(\*) for CLMxxx model keep pushed simultaneously the yellow buttons on both sensors.*

## Job starting

---



Once the machine has been turned on, the following message will be displayed \*\*\*\* meaning no preset function has been selected yet.

In this status you can only count the labels currently loaded and the device will then automatically stop once that roll has run out.

The display will then show the number of labels that has been counted.



Push this button to start the job or follow the setting procedure.

## First setting: COUNTING

---



Push this button to open the setting menu.

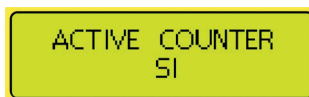

Selecting "YES" will activate the preset function to set the quantity of labels required.

Selecting "NO" will deactivate the preset function, the unit will count the total number of labels available on the loaded roll.



Use these buttons to select “YES” or “NO”

If you choose “YES”, use the buttons below to select the number of labels you want to preset and count.



Use these buttons to select the text to modify.



Use these buttons to assign the value to the digit.

EXAMPLE

COUNTER PROGRAM  
0300

Example of “PRESET” number

## Second setting: UNABLE / DISABLE MISSING LABEL FEATURE

(available on CLMxxx series only)

For CExxx series move to the next setting.

This feature allows the stop of the unit when a label is missing, this function is active after 10 counted labels.

Inside “CLM” menu, the missing label feature will be enabled or disabled through the “TEST ERROR GAP” setting as shown below.

TEST ERROR GAP  
NO



### IMPORTANT

when the unit detects a gap wider than 12mm, it will stop assuming the label is missing.



Use these buttons to select “YES” or “NO”



Push this button to continue the unit setting.

## Third setting: REWINDING ROTATION AND SPEED



Push “PROGR” button to set the rotation setting.

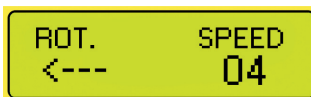

Use these buttons to select the rewinding rotation, face-in or face-out



Use these buttons to choose the rotation speed (from 1 to 10).

***You can increase or decrease the speed at any time during a job by pushing these buttons***



Setting procedure has been completed, push “ESC” to exit from the setting menu.

### EXAMPLE



*with this example of setting, the unit counts 300 labels, it will automatically stop and beep when the preset counting has been reached.*



Push this button to start the job.



When the unit is in action, push this button at any time to interrupt the job. It will open the setting menu

To reset the setting press “PROGR” for 2 seconds.

## Counting manual adjustment

---

Once the media is loaded, the operator can manually increase the “count” value with the number of labels wasted for the media loading.



When the main screen is displayed, push this button to increase the “count” value with the number of labels after the sensor and used to load the media onto the rewinder core.

**Example - 7 labels**



Push this button to reset the count.

## “PLEASE LOAD NEW ROLL” advise

---

When the roll runs out or it is not loaded, the below message will be displayed



Load a new roll and then push progr button for 2 second to reset the unit.

# SMART SOLUTIONS FOR THE LABELING INDUSTRY

Label rewinder, label unwinder, electronic label dispenser and more...

OTHER  
PRODUCTS

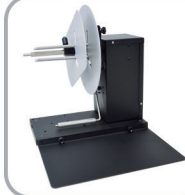

LABEL UNWINDER/REWINDER

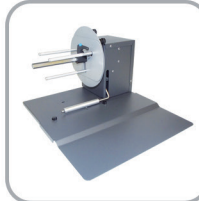

SMALL LABEL  
UNWINDER/REWINDER



LABEL COUNTER



ROLL TO ROLL SYSTEM  
FOR LABEL PRINTERS



ROLL TO ROLL SYSTEM  
FOR EPSON PRINTERS



ROLL TO ROLL SYSTEM  
FOR VIPCOLOR VP SERIES



ROLL TO ROLL SYSTEM  
FOR PRIMERA LX SERIES



MATRIX REMOVER AND SLITTER

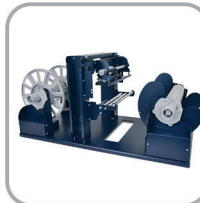

LONGITUDINAL LABEL SLITTER



EASY LABEL DISPENSER



ELECTRONIC  
LABEL DISPENSER



SCORPIO SERIES:  
DIGITAL LABEL FINISHING SYSTEMS



GEMINI:  
DIGITAL DIE CUTTER FOR SHEETS

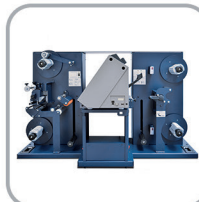

VIRGO:  
DESKTOP DIGITAL FINISHING SYSTEM



MOTORIZED CORE HOLDER  
UNWINDER/REWINDER

- FOR MORE INFO CONTACT YOUR RESELLER -